

GAMMA[®]

PROGRESSION

STII

STRINGING MACHINE

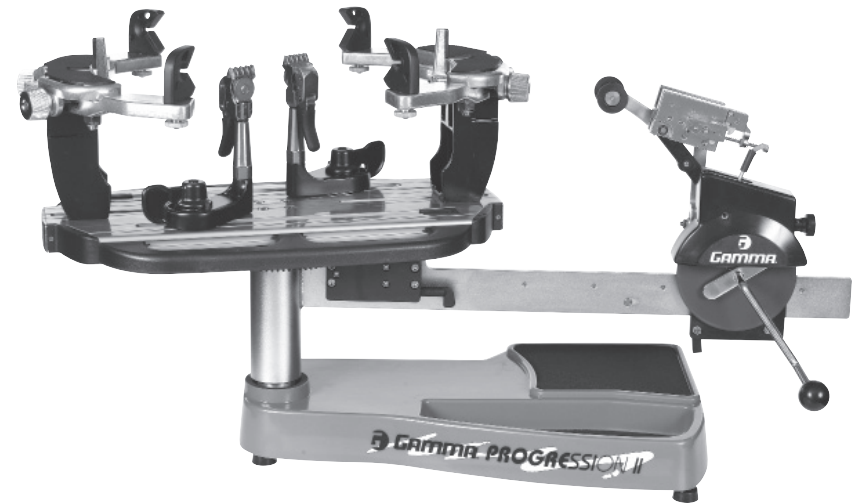

MMAN-31
(MPST2-13)

GAMMA SPORTS
200 Waterfront Drive
Pittsburgh, Pennsylvania 15222
Phone: 800.333.0337 Fax: 412.323.0317
Visit our website at www.gammasports.com

Copyright 2012 GAMMA Sports - All Rights Reserved

OWNER'S MANUAL
Issue 7 - December 2012

PARTS DRAWING

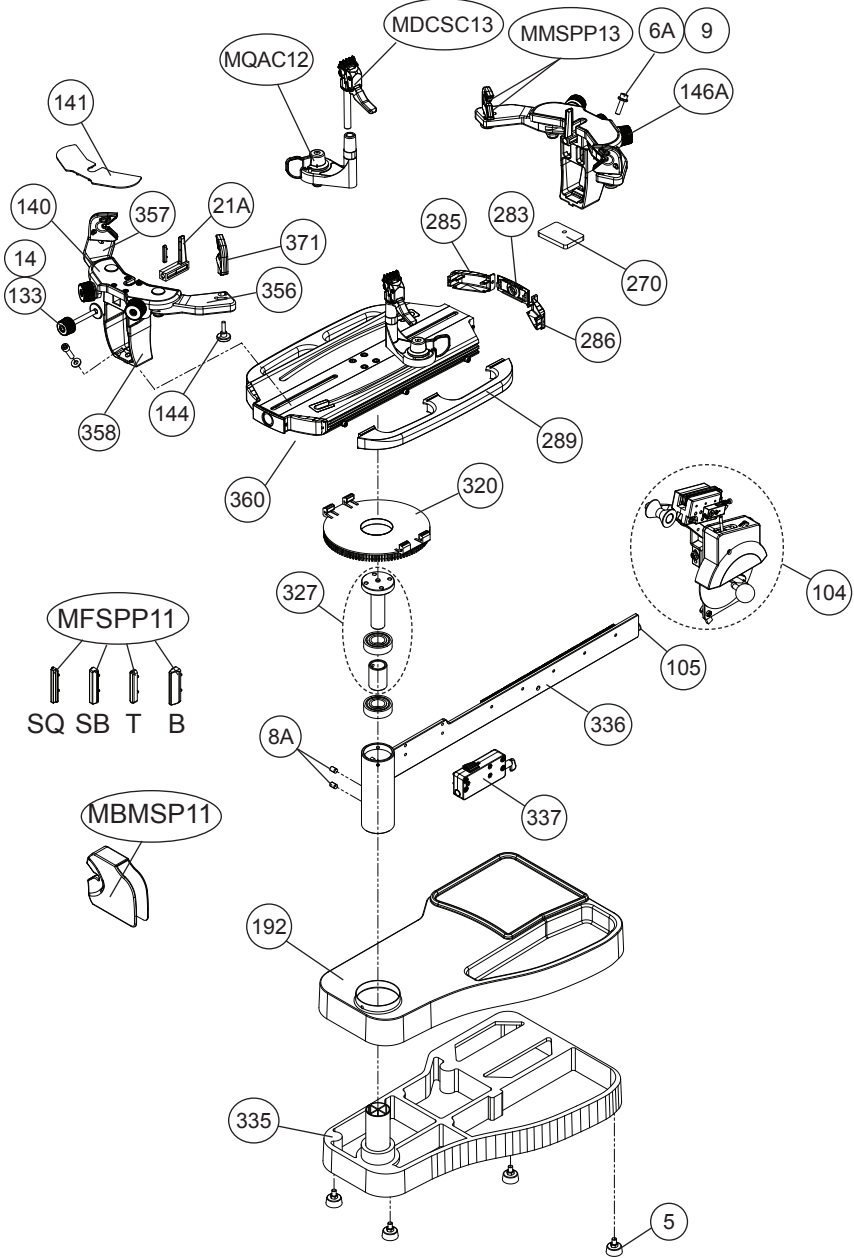

PARTS LIST

PART #	DESCRIPTION	TOOLS & ACCESSORIES	
5	RUBBER FOOT	71	6MM T-HANDLE HEX WRENCH
6A	CAP SCREW- M8x30	98	10MM WRENCH*
8A	SET SCREW	109	NEEDLE NOSE PLIERS*
9	WASHER- M8	110	BENT NOSE PLIERS*
14	WASHER- M10	171	DIAGONAL CUTTERS*
21A	FRAME SUPPORT SLIDE	196	17MM SOCKET*
104	TENSIONER ASSEMBLY	251	HEX WRENCH SET*
105	RETAINER SCREW	MA	STRINGER'S AWL*
133	FRAME SUPP SLIDE SCREW	MFSPP11	FRAME SUPPORT PADS
140	MTNG STAND TOP PLATE		SHORT BADMINTON (SB)
141	MTNG STAND TOP PAD		SQUASH (SQ)
144	SHLDR SUPP LOCK KNOB		TENNIS (T)
146	SUPP ARM ADJUST KNOB		TAPERED BADMINTON (B)
192	PII STII BASE COVER	MMSPP13	V-MNT SHOULDER SUPP PADS
203	TT SCREWS*	MBSMP	BADM SHOULDER SUPP COVER
270	SUPP MOUNTING PLATE	MPSA	PATHFINDER AWL*
283	TT END CAP		*(NOT SHOWN)
285	TT END CAP- RIGHT		
286	TT END CAP- LEFT		
289	TT HANDLES		
320	BRAKE RING		
327	TT PIN		
335	PII STII ALUMINUM BASE	MBFC	BADM FLOATING CLAMP
336	WINDER BAR	MBFS-11	BADM HEAD FRAME SUPP
337	BRAKE BOX	MDCSC	BADM FIXED CLAMP
356	QM ARM (LONG) RIGHT	MGSMC	MACHINE COVER
357	QM ARM (LONG) LEFT	MPG	STARTING CLAMP
358	QM STAND	MPS	CLEANING STONE
360	TURNTABLE TT7	MPXFS	FLOOR STAND
371	SHOULDER V-MNT (BLK)	MTC	CALIBRATOR
MDCSC13	UNIV DC STRING CLAMP	SGSM	STRINGER'S MAT
MQAC12	QA CLAMP BASE TALL TT7/TT8	MBMSS11	BADM MNTNG SYS UPGRADE

OPTIONAL TOOLS & ACCESS

GAMMA®

PROGRESSION STII

OWNER'S MANUAL

TABLE OF CONTENTS

WARRANTY	PAGE 3
FEATURES.....	PAGE 4
ASSEMBLY INSTRUCTIONS	PAGE 5
MOUNTING THE FRAME	PAGE 7
STRINGING THE FRAME.....	PAGE 9
ADDITIONAL FEATURES	PAGE 12
PATHFINDER AWL.....	PAGE 13
MAINTENANCE & ADJUSTMENT	PAGE 14
TROUBLESHOOTING TIPS	PAGE 17
PARTS LIST	PAGE 18
PARTS DRAWING.....	PAGE 19

LIMITED WARRANTY

GAMMA Sports (GAMMA) warrants to the original purchaser that the PROGRESSION stringing machine ("EQUIPMENT") purchased is free from defects in materials and workmanship for a period of five (5) years from the date of original purchase for mechanical parts (excluding electrical parts and string clamps) and for a period of one (1) year from the date of purchase for all electrical parts and string clamps. Should any defects develop under normal use within the specified time periods, GAMMA will at its option, repair or replace the defective EQUIPMENT provided it is returned to GAMMA prepaid at the purchaser's expense. This warranty does not apply to any damage or defect caused by negligence, abuse, misuse, unauthorized alteration, shipping, handling or part wear and tear as a result of normal use.

Routine maintenance, adjustment and cleaning required to ensure proper operation are the responsibility of the purchaser and are not covered under the terms of this warranty. These include, but are not limited to: String Clamp Adjustment, as described on page 16, Tension Calibration, as described on page 14, Tensioner Brake Adjustment, as described on page 15, and Clamp Base Locking Nut Adjustment, as described on page 16.

GAMMA's obligation under this warranty is limited to repair or replacement of defective EQUIPMENT, and no one is authorized to promise any other liability. GAMMA shall in no event be liable for any incidental or consequential damages.

To return defective EQUIPMENT, a return authorization (RA#) must be obtained from a GAMMA customer service representative. The RA# must be marked on the outside of the shipping carton being returned. All returns must be shipped prepaid by the customer to GAMMA. Please retain the original shipping carton and packing materials for any future shipments. GAMMA will not be responsible for machines which are not sent in the original undamaged packaging.

A GAMMA Care Service Plan is also available through GAMMA customer service, call 880.333.0337 for details.

FEATURES

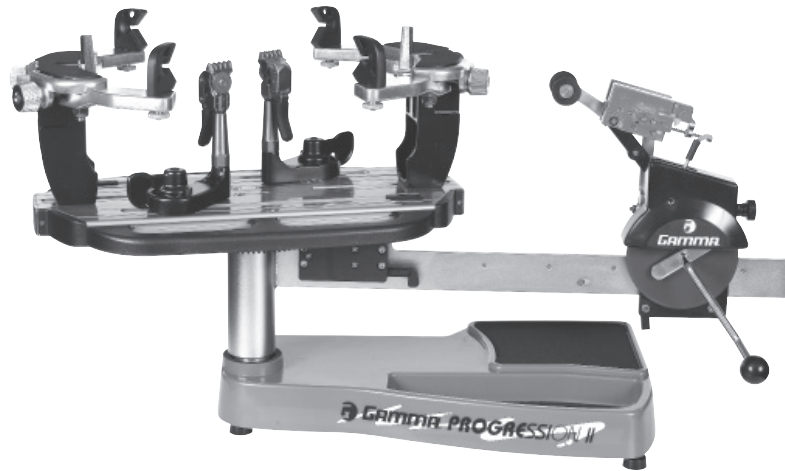

MACHINE FEATURES

- ❖ Manual Spring Tension Winder with 11 to 89 lbs Tension Range
- ❖ Patented Roller Guide for Maximum Accuracy and Consistency
- ❖ Parallel Jaw Gripper with Diamond Dust Coated Gripping Surfaces
- ❖ Professional Six Point “Quick Mount” Racquet Mounting System- Accommodates All Racquets
- ❖ Professional “Quick Action” Dual Action, Rotating, Metal Fixed String Clamps with Diamond Dust Coating
- ❖ Durable Polystyrene Base Cover with Convenient Padded Tool Tray
- ❖ Strong, Light Weight, Aluminum Construction

TROUBLESHOOTING TIPS

<u>PROBLEM</u>	<u>SOLUTION</u>
String slips in clamps	- Adjust gap between clamp jaws - Clean clamp jaws
String slips in gripper	- Clean gripper jaws - Adjust gripper jaw stop screw
String clamp base slips on turntable	- Clean bottom of clamp & top of turntable with alcohol - Adjust clamp base locking nut
Tensioner moves towards racquet after brake lever is released	- Clean tensioner disc brake - Adjust tension brake
String tension too tight or too loose	- Check tension using a tension calibrator, adjust machine calibration if necessary

CARE & CLEANING

With time and use, the clamping surfaces of your machine may become oily or dirty and result in string or clamp slippage while stringing. Periodic cleaning of the String Clamps, String Clamp Base and String Gripper is recommended. Knife sharpening stones work well for cleaning the diamond coated string clamping surfaces. Cleaning with a solvent such as isopropyl alcohol and a mild abrasive tool such as a toothbrush also works well to remove oily or greasy build up.

MAINTENANCE & ADJUSTMENTS

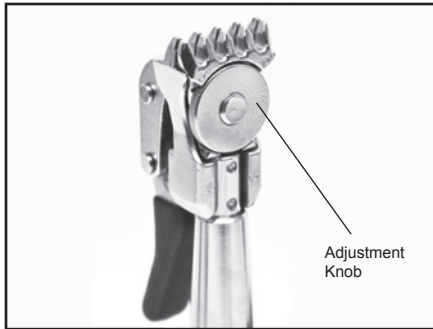

Adjusting the String Clamp Jaw Spacing

The string clamps will need minor adjustments according to what string type, construction, and gauge you are using.

To adjust the gap (clamping pressure) between the clamp jaws, insert the string through the racquet as if you were beginning the main strings. Clamp the strings and pull tension. If the string slips through the jaws of the clamp, tighten the clamp by squeezing the clamp jaws together by hand while turning the Adjustment Knob, in the clockwise direction. If the clamp leaves

impressions or damages the string, it may be excessively tight and should be adjusted by turning the Adjustment Knob counter clockwise to open the gap between the jaws. The clamp jaws should be cleaned periodically to be free from dirt, oil, and any string coating residue to grip properly. Knife sharpening stones are excellent for removing build-up on the diamond coated surfaces and are available.

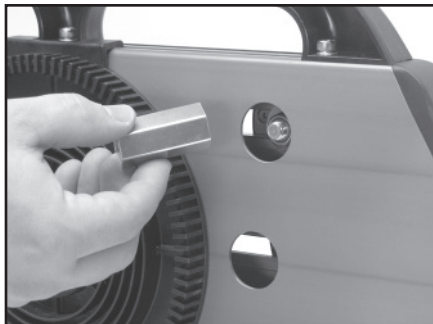

Clamp Base Locking Nut Adjustment

In the event the Locking Lever rotation is insufficient to ensure smooth operation of the clamp base, very minor adjustments to the Clamp Base Locking Nut can be made with the supplied 17mm socket. Tighten or loosen the locking nut in very small increments to provide more clamping pressure or running clearance as needed.

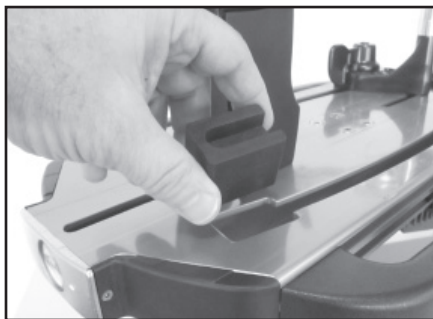

Quick Action Clamp Base Removal

Quick Action clamp bases can be removed from the turntable for maintenance or cleaning by removing clamp stop located at the end of the slot in the turntable. To remove the clamp stop, remove the two screws holding the clamp stop in place from the underside of the turntable. Lift the clamp stop out of the slot, slide the clamp base to the end of the slot and lift it out. Replace the clamp base and clamp stop in reverse order.

ASSEMBLY INSTRUCTIONS

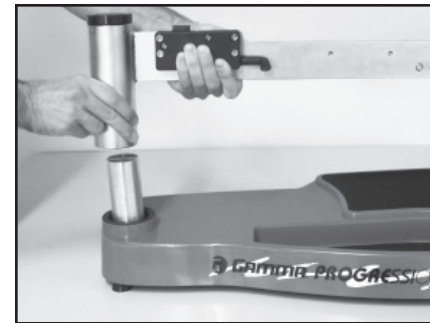

Winder Bar Installation

To install the winder bar, slide over the post on the base and secure it with the 2 allen set screws.

Note: When purchased with the optional floor stand, it is most convenient to attach the base to the floor stand at this point. See instructions provided with the optional floor stand.

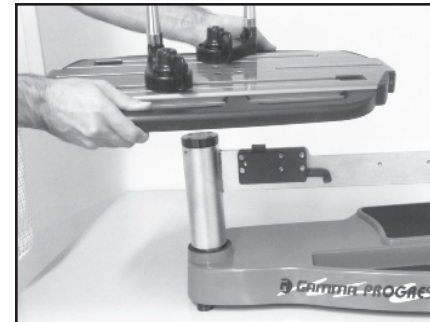

Turntable Installation

To install the turntable position it over the turntable pin and align the bolts (included in separate bag) with the holes in the flange. Secure them with the included 6mm allen wrench.

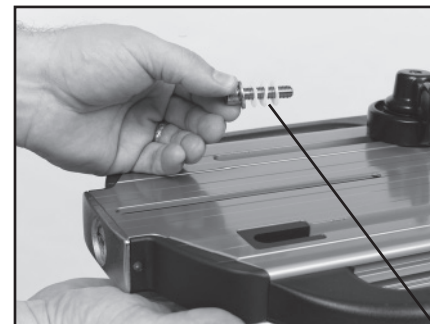

Support Post Installation

To install the support posts you must first remove the mounting bolt from the mounting plate that sets inside the central cavity of the turntable. There are large holes stamped on the underside of the turntable that allow you to support the mounting plate with your fingers while removing the mounting bolt.

After removing the mounting bolt, remove and discard the plastic washers that are installed for shipping purposes.

Remove and Discard Plastic Washers

ASSEMBLY INSTRUCTIONS

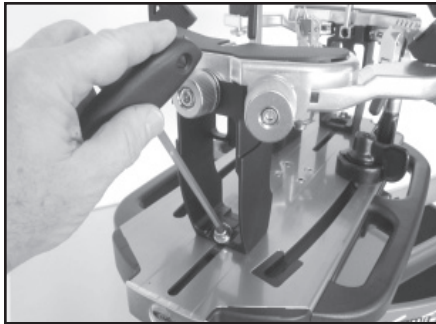

Support Post Installation (cont'd)

Place the support post onto the central slot of the turntable. With your fingers placed through the large hole in the underside of the turntable, press the mounting plate against the inside top surface of the turntable while aligning the hole in the support post with the hole in the mounting plate and fix them with the mounting bolt. Repeat procedure on to attach the support post on the opposite side of the turntable.

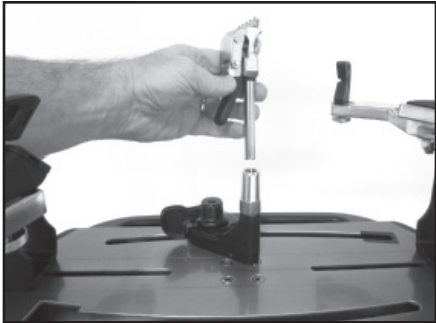

Clamp Head Installation

The post of the string clamp head and tube of the string clamp base are treated with grease to provide protection against corrosion during shipping. Remove any excessive grease with a clean cloth prior to use. The post and tube may also be cleaned with isopropyl alcohol. After this type of thorough cleaning, the post and tube should be treated with a light coating of machine oil to protect the surfaces against corrosion and to ensure smooth operation.

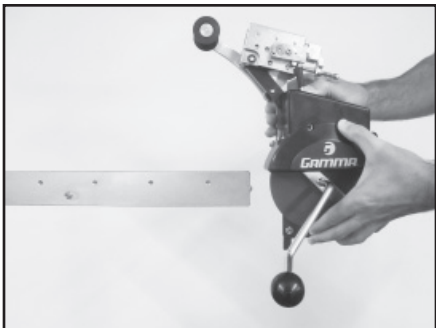

Installing the Tensioner

Remove the button head screw and washer located at the end of the tensioner bar with the 3 mm hex wrench provided. Slide the tensioner onto the bar, being careful to align the bar with all of the bearings and the drive gear with the gear track. Replace the screw and washer into the end of the tensioner bar.

Note: The tensioner bar is equipped with a tensioner travel stop to limit travel of the tensioner along the bar. See page 10 for more details about this feature.

MAINTENANCE & ADJUSTMENTS

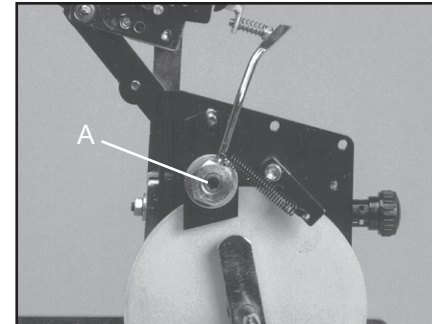

Adjusting the Tensioner Brake

After stringing many racquets, the brake of the tensioner may need to be adjusted.

With the brake lever engaged in the latch, insert the 6mm allen wrench into the bolt (A) located at the base of the brake lever. It can be accessed through the hole on the face of the tensioner cover (above the 'GAMMA' logo).

Note: The tensioner cover does not need to be removed for the adjustment. The cover has been removed in the pictures for illustration purposes.

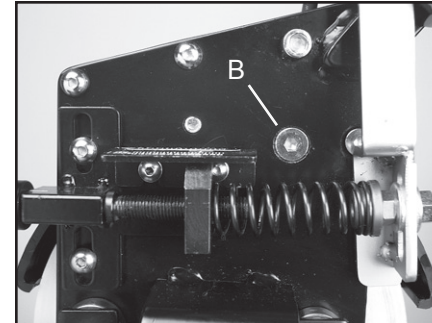

While holding the 6mm brake lever adjustment bolt (A), loosen the hex bolt (B) located on the back side of the tensioner frame with the 4 mm allen wrench.

Note: The hex bolt should only be loosened and must not be completely removed.

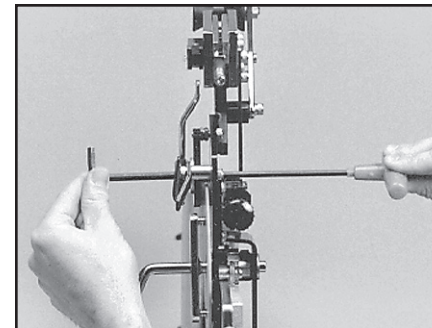

To tighten the braking mechanism, turn the set screw (A) counter clockwise by about 1/8 turn. Re-tighten the allen screw (B) on the back side of the tensioner frame and check for brake tightness. The tensioner should move freely along the track with the brake lever engaged and should hold tension with the brake lever released. If more adjustment is needed, repeat steps above until properly adjusted.

MAINTENANCE & ADJUSTMENTS

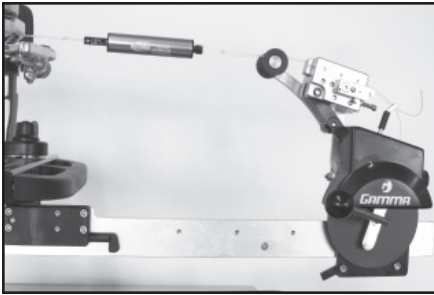

Tension Calibration Procedure

Set the tension to 60 lbs. as indicated by the linear scale and rotary knob. Place the string on one end of a tension calibrator into a string clamp and secure. Place string located on the other end of the calibrator into the string tensioner and apply tension. If the brake lever releases before or after 60 lbs., the tension head should be calibrated as follows.

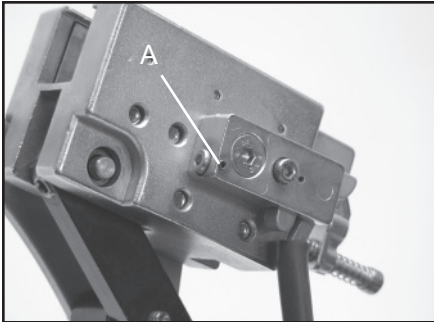

Loosen the 1.5 mm locking set screw (A) located on the side of the latching block as shown. The set screw is used to hold the adjustment screw in place.

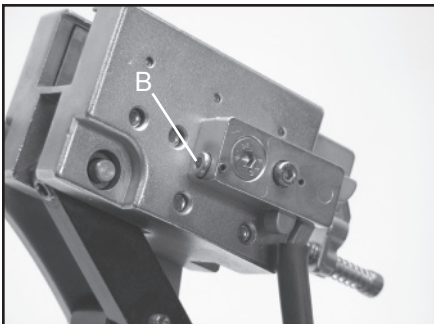

If the lever releases before 60 lbs., using the supplied L-shaped hex wrench, turn the adjustment screw (B) located on the left side of the latch block counter-clockwise to increase the engagement of the brake release latch with the brake lever. Repeat step 1 and adjust until the correct tension is indicated on the calibrator.

If the tension indicated in step 1 is greater than 60 lbs., turn the adjustment screw clockwise to reduce the engagement of the brake release latch with the brake lever. Repeat step 1 and adjust until the correct tension is indicated on the calibrator.

Tighten locking set screw (A) when finished.

MOUNTING THE FRAME

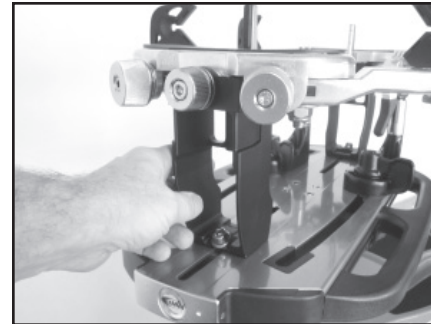

Adjusting the Frame Support Posts

Loosen the lock bolts of the frame support posts and space them apart with the frame support slides separated by the approximate length of the racquet head. Although it is not required, it is good practice to center the support posts on the turntable. Lock one of the posts in position by tightening the lock bolt and position the other post until the frame support slide is positioned near the inside surface of the racquet frame. Securely tighten the lock bolt of the second support post.

Caution: To avoid racquet damage, the center posts should not contact the racquet prior to locking down the support posts.

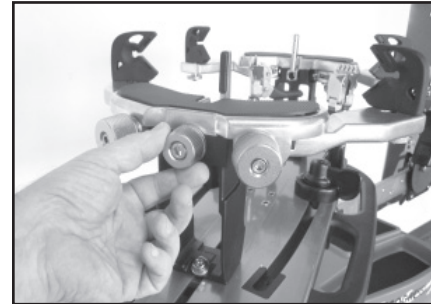

Tightening the Frame Supports

Tighten the Frame Support Slides by turning the adjustment knob clockwise until snug against the racquet frame and slight resistance is felt.

Caution: Overtightening the Center Supports will stretch the head of the racquet and could cause racquet damage.

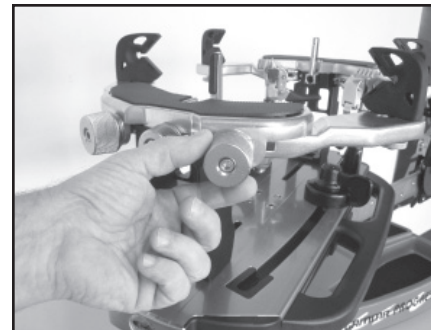

Frame Shoulder Support Adjustment

Being sure the shoulder supports are free to swivel in their mountings, simultaneously rotate the shoulder support adjustment knobs clockwise until both shoulder supports gently and squarely contact the frame.

MOUNTING THE FRAME

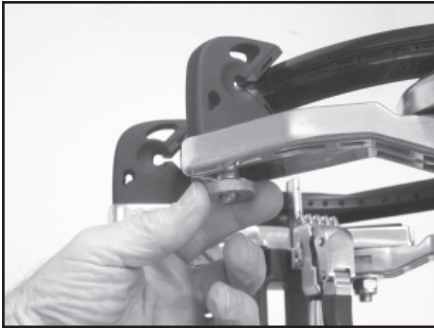

Securing the Frame Shoulder Clamps

Lock the shoulder supports in position by turning the knob at the base clockwise.

Repeat the adjustment procedure for the remaining support post.

Re-tighten all of the frame supports in the same order as before.

Do not overtighten any of the supports as racquet damage may occur.

The supports should be tightened to the point where the racquet frame will not move in the mounting system when the handle is grasped and attempts are made to move it. Should any supports lose contact with the frame while stringing, they should be re-tightened.

PATHFINDER AWL

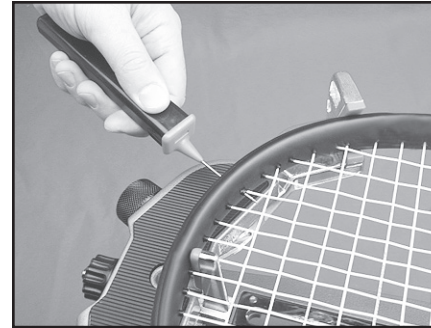

The machine includes the pathfinder stringing awl which creates a pathway between or around strings to make inserting a string through blocked grommets easier and quicker.

Insert the awl through the grommet hole in the same manner as for traditional awls. The pathfinder awl must be in the closed position before insertion.

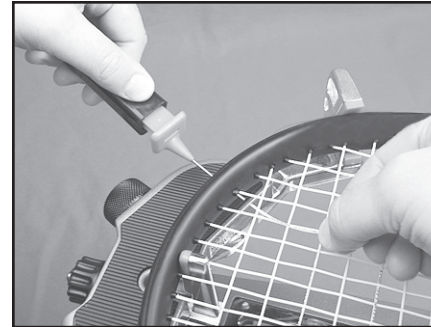

Once the awl is inserted, pull the handle of the awl outward while holding the tip section in place. This leaves the outer sheath in the grommet hole. Insert the end of the string into the outer sheath.

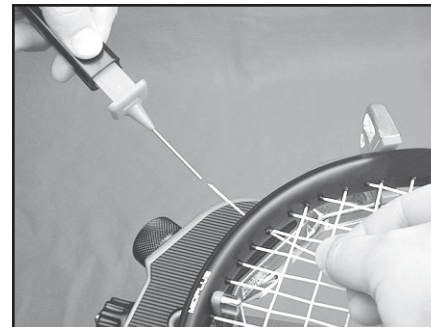

While holding the string, slowly pull the sheath out of the grommet hole to leave the free end of the string exposed.

ADDITIONAL FEATURES

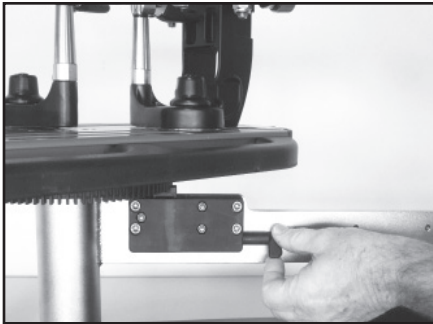

Locking the Turntable

The turntable may be locked in any position. Rotate the lever down to lock the turntable and up to release the turntable.



Badminton Shoulder Support Protection Pad Installation

Slide the badminton shoulder support cover over the shoulder supports. There is no need to remove the tennis shoulder supports.

Note: An optional badminton frame support for the head of the racquet is available.

STRINGING THE FRAME

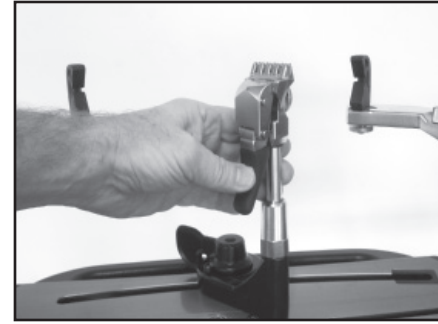

Clamp Head Operation

Quick Action Clamps are of a dual action design where the clamp head and clamp base operate independently of one another.

To clamp a string, lift the clamp head and place the string between the jaws and depress the clamp head lever to secure the string. The clamping pressure applied to the string should be adjusted to provide sufficient pressure to secure the string when subjected to the desired pulling tension. The diamond coated gripper plates provide for increased friction between the clamps and the string

to allow for reduced clamping pressure while securing and holding the string under tension.

Note: If the string slips in the string clamp while tensioning, adjust the gap between the clamp jaws per the instructions on page 16.



Clamp Base Operation

Rotate the Base Locking Lever clockwise to secure the clamp base to the turntable.

Reverse the clamping procedure to unlock the string clamp. The Locking Lever is spring loaded to assist the unlocking of the clamp base.

The Locking Lever should be tightened enough to prevent clamp base slippage on the turntable, when the desired tension is placed on the string. To go from the loose position to the clamped position and back, generally requires the rotation permitted by the slot in the clamp base. If the rotation is not sufficient to allow smooth operation of, adjust the Clamp Base Locking Nut as outlined on page 16.

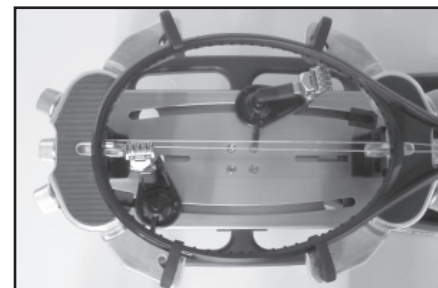

Clamping the First Main String

To begin stringing the main strings, thread the two ends of the string through the two center holes at the appropriate end of the frame and continue through the opposite center holes. Thread one end of the string through the adjacent grommet hole and pull excess by hand.

Secure one of the strings using a string clamp.

STRINGING THE FRAME

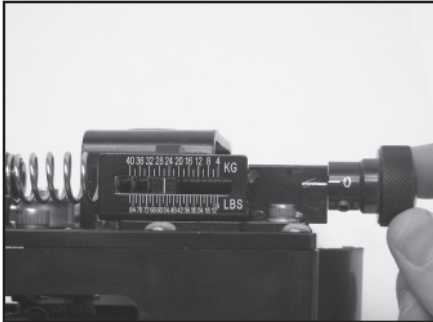

Setting Tension

The STII utilizes a rotary adjusting knob along with a linear tension scale to indicate the tension setting. The scale is divided into 3 lb. increments and each 1/3 turn of the tension knob changes tension by 1 lb. To set the desired tension, rotate the tension knob and align the mark on the spring guide with the desired tension setting on the scale. When the "0" mark on the knob aligns with the line on the knob support the tension will be that indicated on the scale. To increase tension by 1 or 2 lbs. turn the knob counterclockwise

until the "1" or "2" mark on the knob aligns with the line on the knob support. To decrease tension by 1 or 2 lbs., turn the knob clockwise until the "2" or "1" mark on the knob aligns with the line on the knob support.

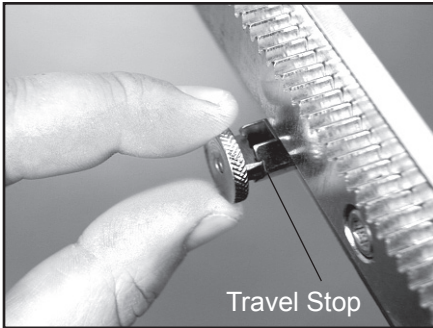

Tensioner Travel Stop

The tensioner bar is equipped with a tensioner travel stop to limit travel of the tensioner along the bar and prevent contact between the tensioner and the racquet mounting system while stringing. The travel stop is located about midpoint along the tensioner bar below the gear track.

To disengage the stop, pull and hold the knob, rotate 90 degrees and release. To engage the stop, repeat the above procedure until the travel stop pin protrudes beyond the opposite surface of the tensioner bar.

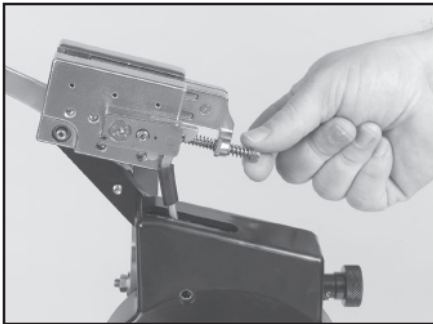

Setting the Gripper Jaw Spacing

The gripper jaws of the tensioner are adjustable to accommodate varying string gauges.

If the string slips through the gripper jaws while pulling tension, rotate the gripper jaw adjustment screw counter-clockwise.

If the string is damaged while pulling tension, rotate the gripper jaw adjustment screw clockwise.

The jaws will be properly adjusted when there is enough pressure to securely grip the string without causing damage to the string.

STRINGING THE FRAME

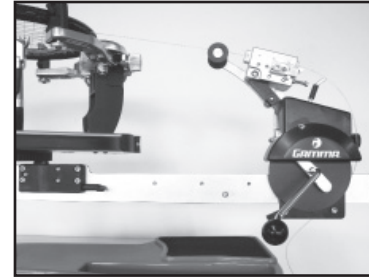

Pulling Tension

Wrap the loose section of string once around the roller guide and insert the string between the diamond dust coated string gripper plates. Pull the string perpendicular to the gripper plates while slowly rotating the tensioner crank clockwise until the brake lever pops out of the latching block. The string is now tensioned and can be clamped in place with the remaining fixed clamp.

Repeat the above steps until all main strings are installed. Tie off ends of main strings as per racquet

manufacturers recommendations.

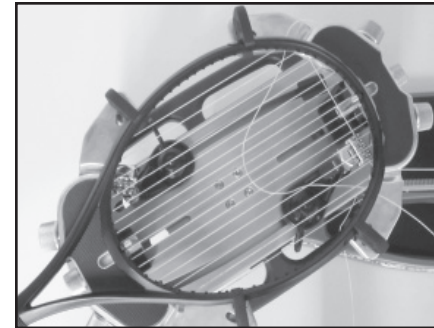

Weaving the Cross Strings

Weave the cross strings over and under the main strings being careful to alternate the weave direction of each consecutive cross string so as to be opposite of the previously installed cross string.

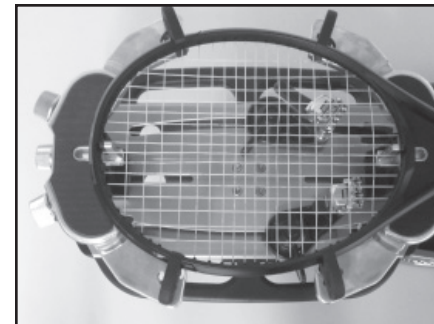

Once the final cross string is tensioned and clamped, tie off at the appropriate hole specified by the racquet manufacturer.